

Pulled briskly along with oars, pushed along by an outboard, or riding easily under sail, *Sea Midge* will find a wide variety of uses for sport and relaxation—and the serious work of fishing.

SEA MIDGE

Snug, Small, Three-Way Pram

By WILLIAM D. JACKSON
Naval Architect

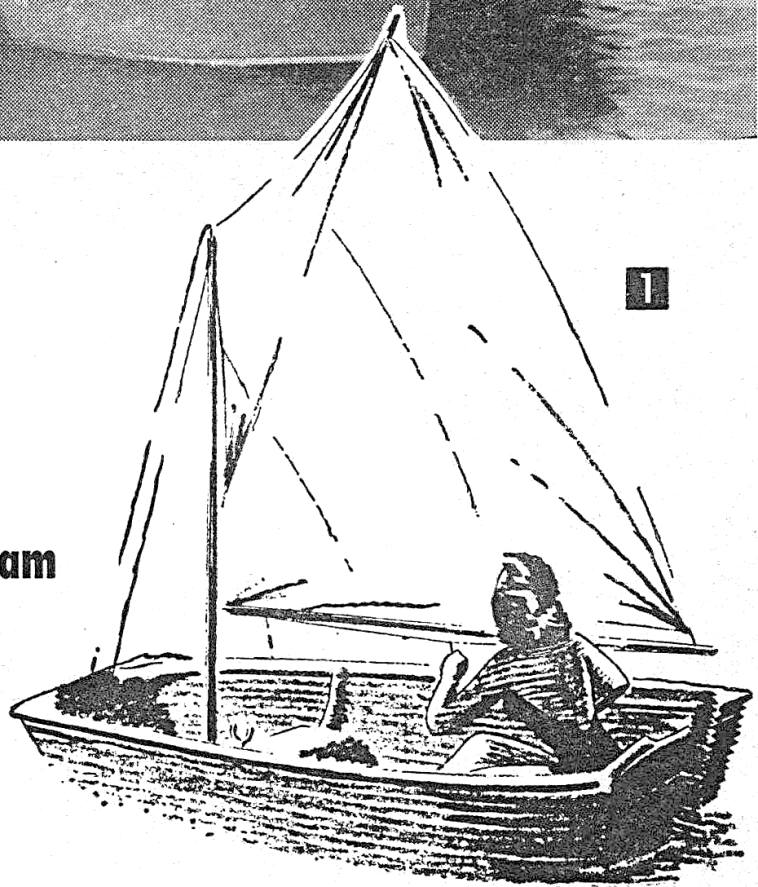

DESIGNED with a convex bottom for maximum speed whether powered by sail, outboard motor or oars, *Sea Midge* is modeled on an Old World boat originally developed as a yacht dinghy for use upon the North Sea. It is an excellent all-around work-horse and is light enough to be carried anywhere.

Construction of *Sea Midge* is simplicity itself. The first item of construction is the building form (Fig. 2). Next, make mold frames #1 and #2 as shown in Fig. 3, using as patterns full-size drawings of these parts drawn on heavy brown wrapping paper. Nail at joints, and slip molds into notches on building form.

Using full-size paper patterns again, cut the backing for the stem and the transom from $\frac{3}{8}$ -in. plywood to the shapes shown in Fig. 3, their frames from $\frac{3}{4}$ -in. oak (or fir) stock and glue-coat all contacting surfaces with *Weldwood* before fastening from plywood to frames with #8 x 1-in. *fh* screws. Clamp stem and transom to building form with Jorgenson's C-clamps.

Mark all frames for the keelson and make notches for this member with a hand saw and



Craft Print Project No. 274

STATEMENT OF USES

USES: May be rowed or sailed or adapted for use with outboard motors of from 1 to 3 hp.

TYPE: Pram type.

LENGTH: 8 ft. over-all; 6 ft. 6 in. on water line.

BEAM: 52 in. at widest point; 45 in. at water line.

DEPTH: 16½ in.

WEIGHT OF HULL: 65 lbs.; spars, 10 lbs.

CAPACITY: Seats two persons.

CONSTRUCTION: ¼-in. exterior waterproof plywood over a stressed framework, hull built over two mold frames which are later removed.

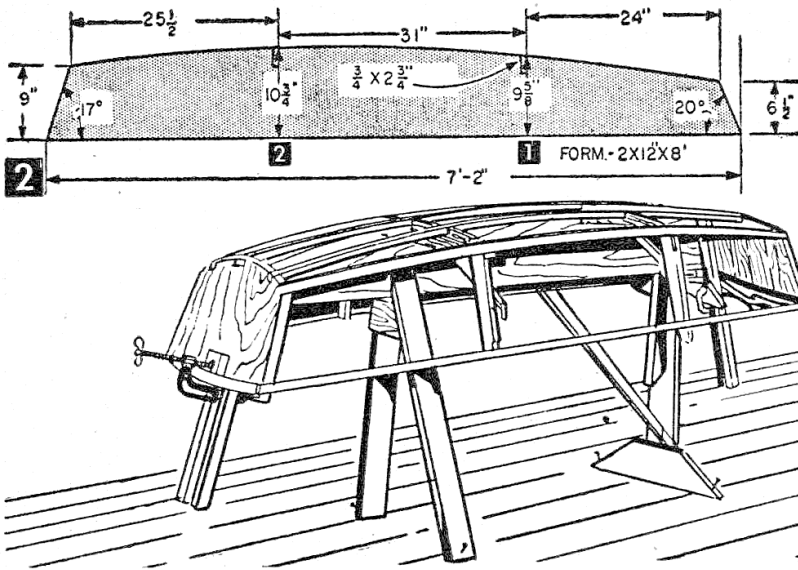

Slit the 4 x 8-ft. sheet of 1/4-in. plywood to be used for bottom planking into two 2 x 8-ft. pieces by sawing down center. Draw center line down keelson, lay edge of one of the 2 x 8-ft. pieces on this line, clamp in position and mark to shape with keelson's centerline. Remove and trim for even fit at centerline, reposition and clamp and mark underside of outer edges along chine edge of hull. Remove and trim to shape, then follow the same procedure for the other 2 x 8-ft. planking piece. Gluecoat "faying" surfaces (the nautical name for adjoining surfaces), clamp bottom pieces in place and screw-fasten to all of framing except mold frames with #8 x 1-in.

chisel, beveling to follow sweep of hull lines, using a wood rasp for close fit. Fasten keelson to transom and stem only with two #8 x 1 3/4-in. fh screws at each joint, drilling lead holes for these fastenings and countersinking them fairly deep so that the keelson can be planed flush later. Next, make notches for chines and fasten them in place with one #8 x 1 3/4-in. screw at each joint. Temporarily secure to mold frames with either nails from molds to chines or with a small angle iron, screwfastened with #8 x 3/4-in. fh screws removed before planking. Notch for clamps and screwfasten as with chines, trimming all framing members flush with the 3/8-in. backing of transom and stem frames. Finally, notch two bilge battens into stem and transom (see Figs. 3 and 4) and screwfasten with #8 x 1 3/4-in. fh screws, one to a joint.

fh screws (or 1 x 14 Stronghold or Anchorfast nails). Space screws about 2 in. apart and stagger them slightly to prevent splitting.

When glue has dried, trim edges of bottom plywood evenly along chines, stem and transom and if you have made an opening in keelson for a centerboard, make this opening in bottom plywood also. Apply sides in the same manner as you applied bottom, place planking piece along side, clamp in position, mark to shape, remove and saw to size, gluecoat adjoining surfaces, screwfasten and trim. Then install outer keel to cover keel seam, screwfastening with #8 x 1 1/4-in. fh screws spaced about 6 in. apart. If centerboard is used, cut out keel for well slot.

Now remove hull from building form, leaving the mold frames in place until hull is right side up. Pull top of sides slightly apart and pull out mold frame #2, tacking a 3/4 x 2-in. wood

Now, using a plane and wood rasp (or a Stanley "Surform"), trim and fair entire framework so that sheet plywood planking will lie evenly at all points. And if you are going to use your *Sea Midge* as a sailer, now is the time to cut an opening in the keelson for a centerboard and case as indicated in Fig. 4, drilling 3/4-in. holes at ends of location and chiseling or sawing out rest of opening. Cover exposed framing members at stem and transom with 1/4-in. plywood frames (see Fig. 8) glued into position with *Cascomite* or *Weldwood*, clamped until dry, and you're ready to plank hull.

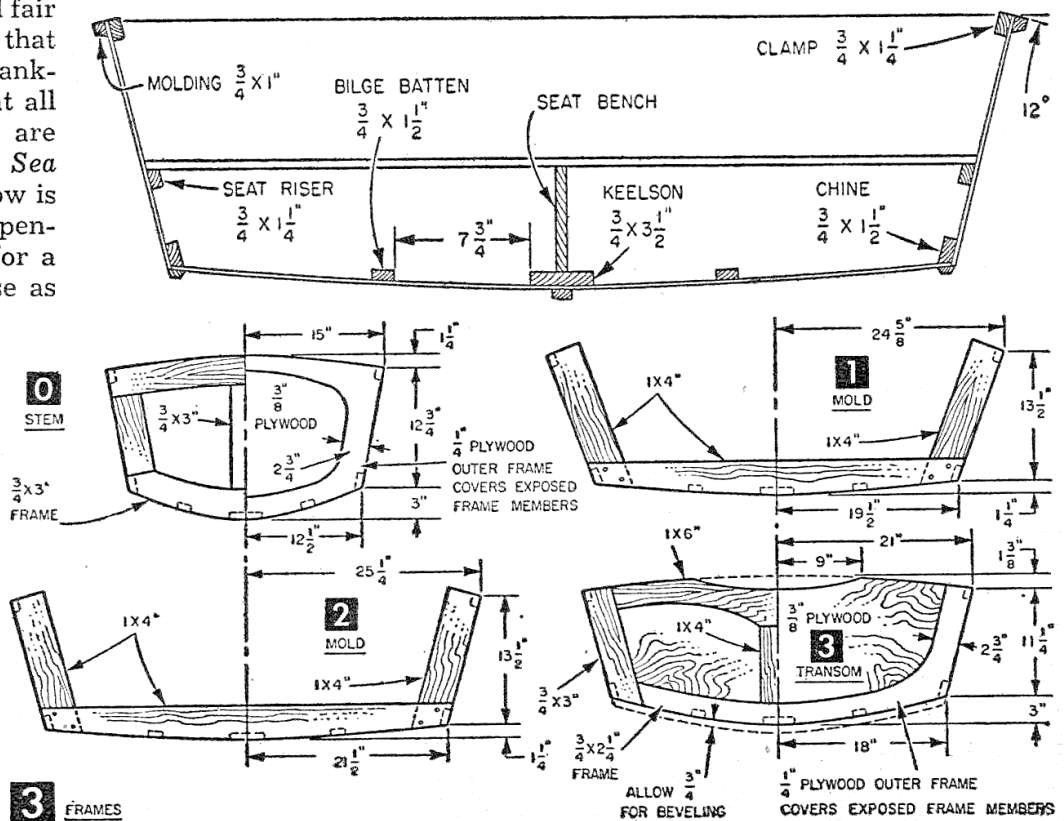

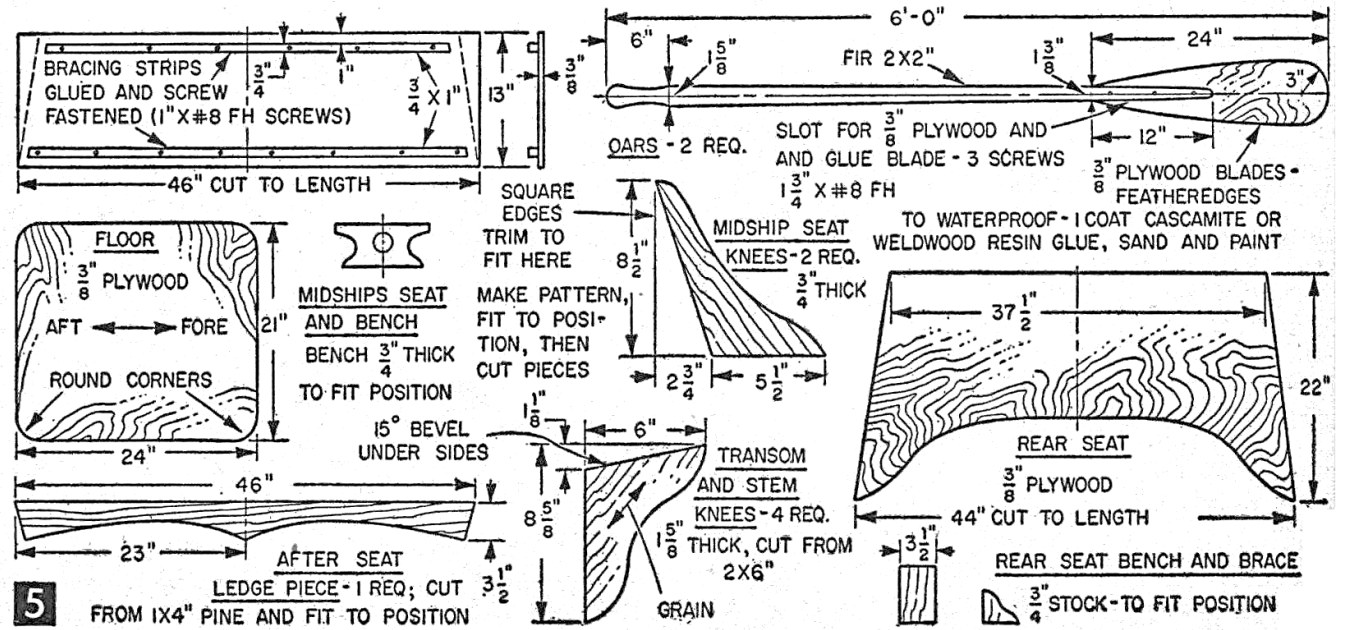
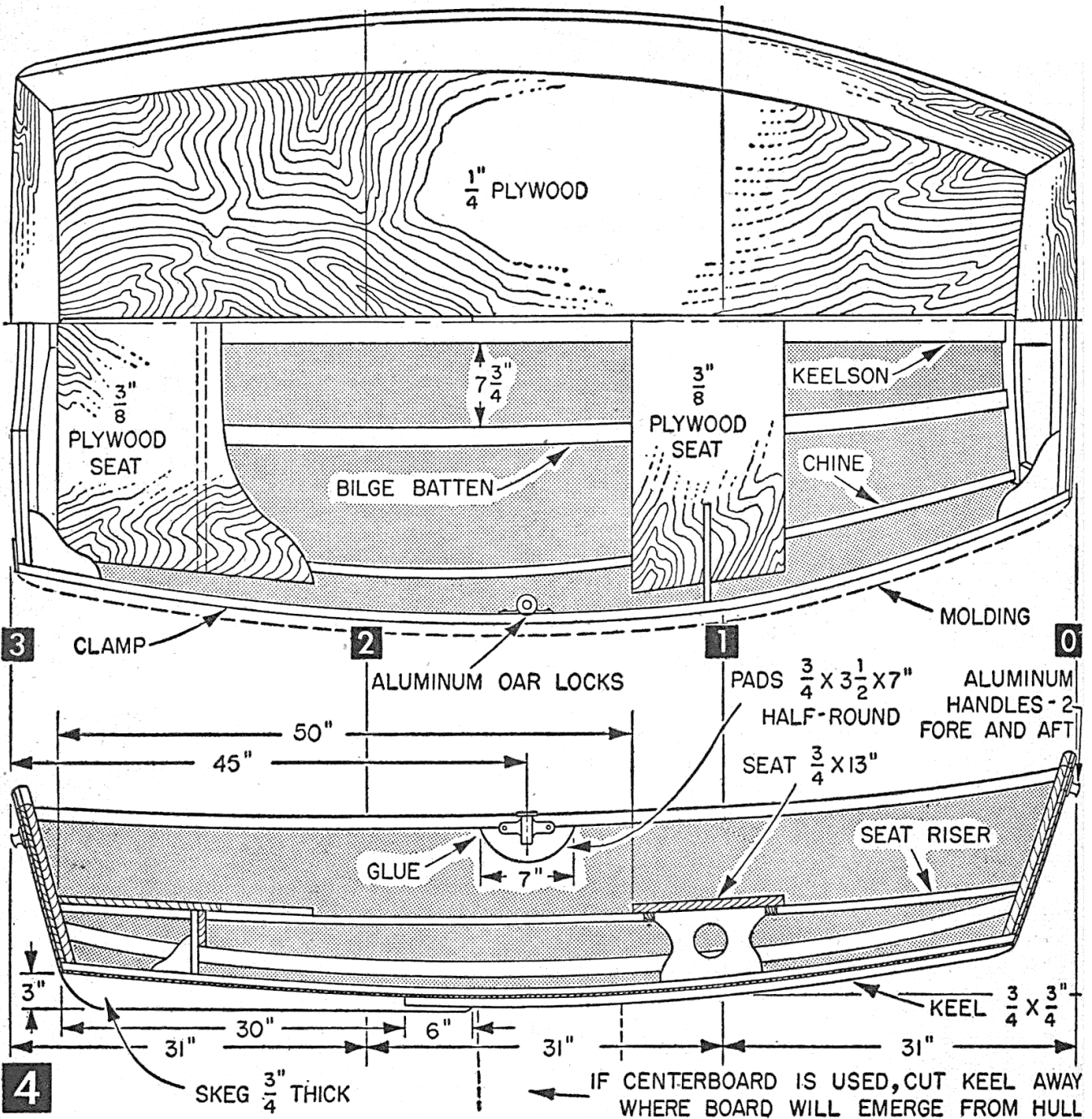

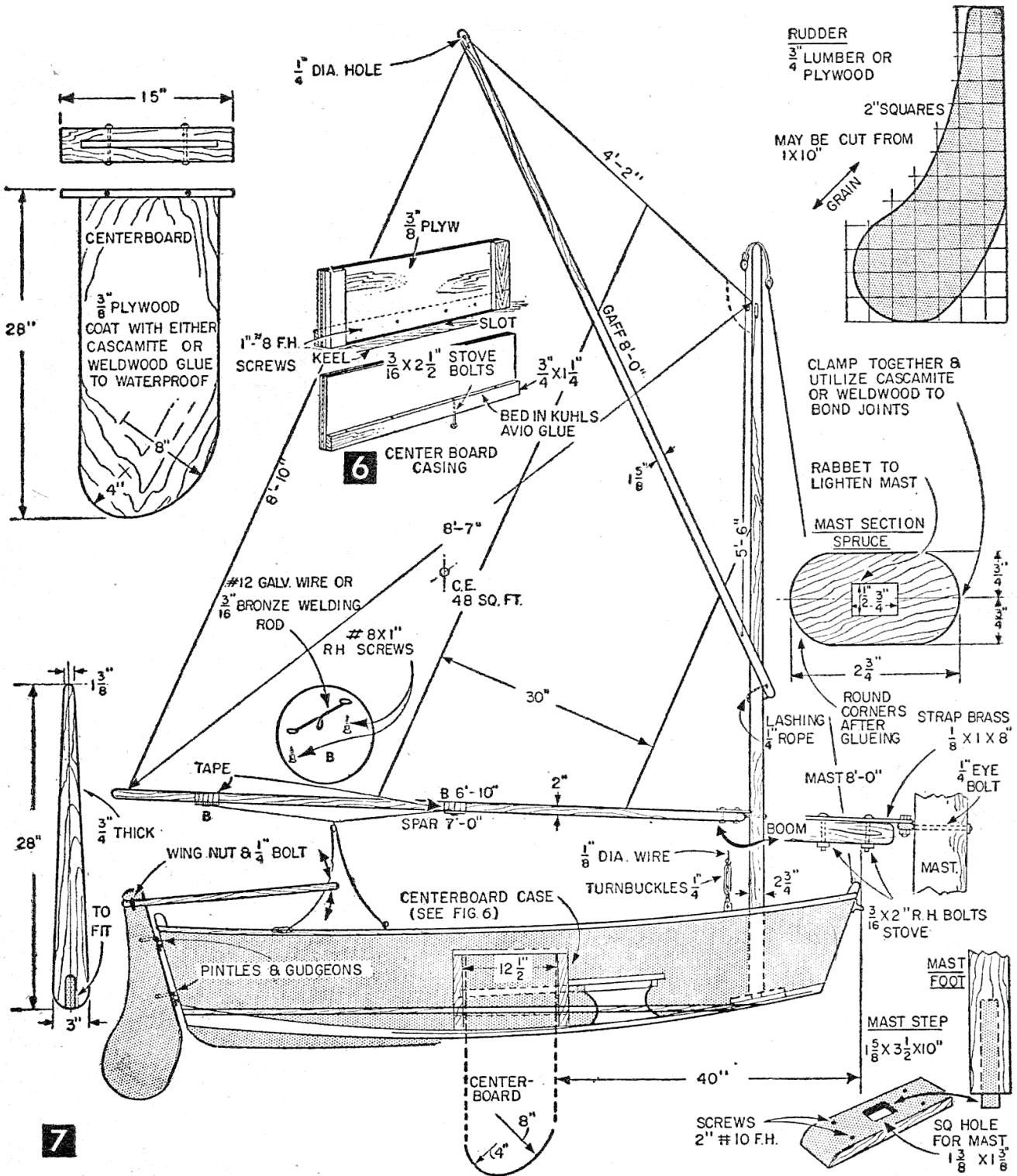

strip across top of hull to maintain its shape; then pull out mold frame #1 and interior of hull is ready to work upon.

The seat risers (Figs. 3 and 4) are the first members placed inside the hull. Spring into place and screwfasten from plywood sides with #8 x 1-in. fh screws spaced about 4 in. apart. Fit stern and transom knees in place (hull interior members which require patterns are detailed in Fig. 5) and screwfasten with four #9 x 2-in. fh screws to each knee. Cut midships seat from 3/8-in. plywood to fit position and brace with strips as indicated in Fig. 5. After screwfastening midships seat to side knees with #8 x 1 1/4-in. fh screws from underside of seat,

fasten seat bench to keelson with two #8 x 1 3/4-in. fh screws and position seat and fasten to risers and bench with nine #8 x 1 1/4-in. fh screws, three to a joint. Screwfasten knees from plywood planked sides with #8 x 1 1/4-in. fh screws.

Fasten ledge piece of the after seat to the sides of boat and support (Fig. 4) with #8 x 1 3/4-in. fh screws. Place after seat in position and screwfasten to ledge piece and from sides and transom with #8 x 1 1/4-in. fh screws. Cut moldings for sides and fasten at the sheer line with #8 x 1 1/2-in. fh screws spaced at 6-in. intervals, round off ends of moldings and turn the hull bottom side up for finishing touches.

MATERIALS LIST—SEA MIDGE

No.	Size and Description	Use	No.	Size and Description	Use
	Plywood				
2 pcs	1/4" x 4 x 8' Ext. DFPA Fir, AA Grade	bottom and sides	1 pc	3/4 x 5 1/2 x 18"	fore seat knees
1 pc	3/8" x 4 x 8' Ext. DFPA Fir AC Grade	transom, stem, and seats (also centerboard)	1 pc	1 5/8 x 11 1/2" x 8' (2 x 12" x 8')	building form
2 pcs	3/4 x 1 1/2" x 8'	chines	2 pcs	3/4 x 5 1/2" x 8' (1 x 8" x 8')	transom and stem framing
1 pc	3/4 x 3 1/2" x 8'	keelson	Fastenings		
1 pc	3/4 x 1 1/2" x 8'	keel	4 gross	#8 x 1" fh screws or 1 lb. 1 x 12 Stronghold nails, hot-dipped galvanized	
2 pcs	3/4 x 1 1/4" x 8'	clamps	4 doz	#8 1 1/4" fh screws	
2 pcs	3/4 x 1 1/4" x 8'	seat risers	3 doz	#8 1 1/2" fh screws	
2 pcs	3/4 x 1" x 8'	moldings	2 doz	#8 1 3/4" fh screws	
2 pcs	3/4 x 1 1/2" x 8'	bilge battens	1 qt	Maurice Condon's Boatlife (clear or colors)	
1 pc	1 5/8 x 5 3/4" x 2' (2 x 6" x 2')	knees	4	aluminum lifting handles	
			2	aluminum oar locks	
				(materials required to build as sailer shown in Fig. 7)	

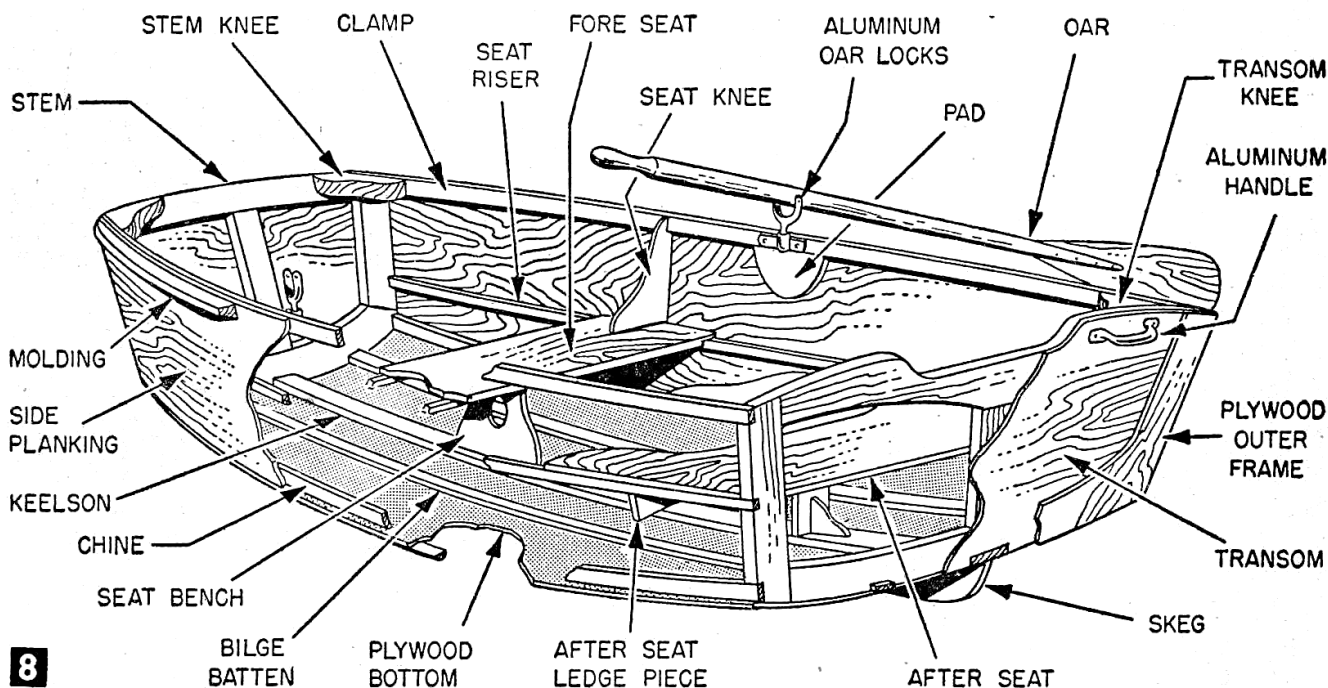

8

You can waterproof chine joints of plywood with 1/2 x 3/4-in. wood strips along chine edges as we did, using Kuhls *Avio Glue* between contact surfaces and strips and screwfastening with #6 x 1-in. fh screws, or you can waterproof with 3-in. *Castoglas* tape and polyester resin. It will take 7 yds. of tape to cover seams. The four aluminum lifting handles, two forward and two aft, are used to lift *Sea Midge* and also to secure it to an auto-top carrier when it is being transported. Oarlocks are purchased and installed as shown in Fig. 4; oars can also be purchased, or they can be made as shown in Fig. 5.

Turn hull right side up again and make floor board (Fig. 5). Finish inside of hull, and both sides of floorboard with three coats of *Condon's* clear *Boatlife* and follow by screwfastening floorboards to keelson and bilge battens with #8 x 1 1/4-in. fh screws, placing 3/16-in. or 1/4-in. washers under the screwheads so that this floor can be readily removed for cleaning of boat. Sides of *Sea Midge* can take either clear or Eggshell

White *Boatlife*, three coats, while bottom looks attractive finished in Cape Cod Green or Chinese Red.

If you're building *Sea Midge* as a sailer, Fig. 7 shows you how. You can make your sails or have Alan-Clarke, 96 Chambers St., New York, make them for you. In either case, you'll find that although no amount of power will initiate planing, *Sea Midge* is a great deal faster than most other flat-bottom prams, that it handles better and that it is also stronger.

● Craft Print No. 274 in enlarged size for building *Sea Midge* is available at \$1.50. SPECIAL QUANTITY DISCOUNT! If you order two or more craft prints (this or any other print), you may deduct 25¢ from the regular price of each print. Hence, for two prints, deduct 50¢; three prints, deduct 75¢, etc. Order by print number. To avoid possible loss of coin or currency in the mails, we suggest you remit by check or money order (no C.O.D.'s or stamps) to Craft Print Dept. B58, SCIENCE AND MECHANICS, 450 East Ohio Street, Chicago 11, Illinois. See coupon on page 192. Now available, our new illustrated catalog of "186 Do It Yourself Plans," 10¢. Please allow three to four weeks for delivery.

